

ISOMETER® IR423

Insulation monitoring device for mobile generators





Device features

- Insulation monitoring for mobile generators AC 0...300 V
- Protection by electrical separation with insulation monitoring and disconnection
- Version "W" for protection against high mechanical stress
- Two separately adjustable response values
- Connection monitoring system/earth
- Power On LED, alarm LEDs: Alarm 1, Alarm 2
- Internal/external test/reset button
- Two separate alarm relays (one changeover contact each)
- N/O or N/C operation, selectable
- Fault memory behaviour, selectable
- Self monitoring with automatic alarm
- Multi-functional LC display
- Adjustable response delay
- Two-module enclosure (36 mm)
- Push-wire terminal (two terminals per connection)

Approvals



Product description

The ISOMETER® of the IR423 series monitors the insulation resistance R_F of an unearthed AC system of 0...300 V to earth that is supplied by a mobile generator. The IR423 is suitable for AC systems with operating frequencies ≥ 30 Hz as well as for AC systems with directly connected DC circuits. The maximum permissible system leakage capacitance C_{emax} is 5 μF .

Application

- IEC 60364-7-717, DIN VDE 0100-717 (2005) Electrical installations in mobile or transportable units
- DIN VDE 0100-551 (VDE 0100-551), IEC 60364-5-551 Low-voltage generating sets (mobile generators)
- GW 308 "Mobile Stromerzeuger für Rohrleitungsbaustellen 8/00" (Mobile auxiliary power generators on pipeline site") (DVGW)
- BGI 867 (German Berufsgenossenschaft Information) Auswahl und Betrieb von Ersatzstromerzeugern auf Bau- und Montagestellen (Selecting and operating standby generators on construction and installation sites)

Function

The currently measured insulation resistance is indicated on the LC display. In this way, any changes, for example, when circuits of loads are connected to the system, can be recognised easily. When the value falls below the preset response values, the response delay " t_{on} " starts. Once the response delay " t_{on} " has elapsed, the alarm relays "K1/K2" switch and the alarm LEDs "AL1/AL2" light up. Two separately adjustable response values/alarm relays allow a distinction to be made between prewarning and alarm. If the insulation resistance exceeds the release value (response value plus hysteresis), the alarm relays return to their initial position. If the fault memory is enabled, the alarm relays remain in the alarm state until the reset button is pressed or until the supply voltage is switched off. The device function can be tested using the test button. The parameterisation of the device can be carried out via the LC display or the function keys integrated in the front plate.

Connection monitoring

The connections to the system (L1/L2) and earth (E/KE) are either automatically checked every 1 h, or by pressing the test button or when supply voltage is applied. In case of interruption of a connecting lead, the alarm relay K2 switch, the LEDs ON/AL1/AL2 flash and the following message appears on the display:

"E.02" signals a fault in the connecting leads to the system,

"E.01" signals a fault in the connecting leads to PE.

After eliminating the fault, the alarm relays return to their initial position either automatically or by pressing the reset button.

Measurement method

The ISOMETER® of the IR423 series uses a modified measurement method specially suited for mobile power generators (also for inverter technology).

Standards

The ISOMETER® of the IR423 series complies with the requirements of the device standards:

- DIN EN 61557-8 (VDE 0413-8),
- EN 61557-8,
- IEC 61557-8,
- IEC 61326-2-4,
- DIN EN 60664-1 (VDE 0110-1),
- DIN EN 60664-3 (VDE 0110-3),
- ASTM F1669M-96 (2007),
- ASTM F1207M-96 (2007)

Operating elements

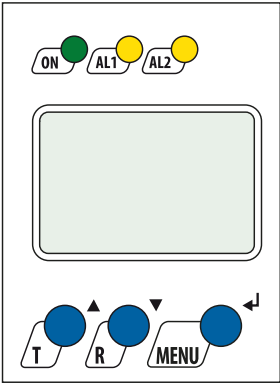
Device front	Element	Function
	ON	green - On
	AL1	yellow - Pre-warning
	AL2	yellow - Alarm
	▲ T	Up button Test button (press > 1.5 s) By pressing and holding the test button, the display elements are indicated.
	▼ R	Down button Reset button (press > 1.5 s)
	↵ MENU	ENTER MENU button (press > 1.5 s)

Wiring diagram

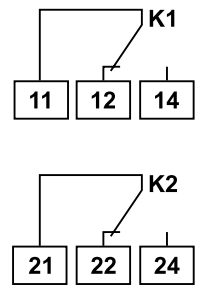
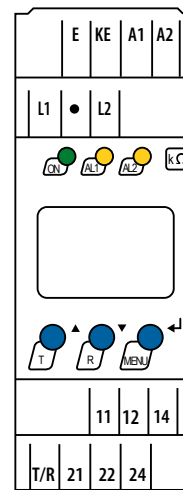
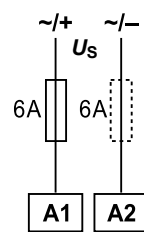
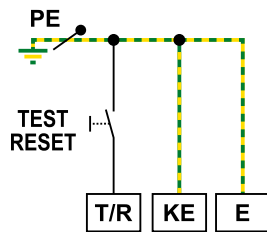
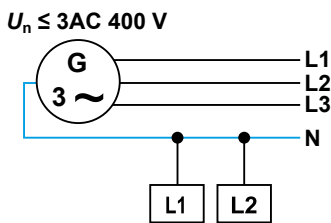
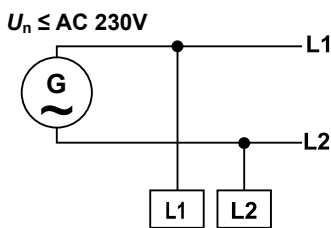

A1, A2	Supply voltage U_s (see ordering details) via fuse
E, KE	Separate connection of E, KE to PE
L1, L2	Connection of the AC system to be monitored: AC: connect terminals L1, L2 to conductor L1, L2.
11, 12, 14	Alarm relay "K1": Alarm 1
21, 22, 23	Alarm relay "K2": Alarm 2

T/R	Combined test and reset button "T/R": short-time pressing (< 1.5 s) = RESET, long-time pressing (> 1.5 s) = TEST
	Line protection by a fuse in accordance with IEC 60364-4-43 (6 A fuse recommended). In case of supply (A1/A2) from an IT system, both lines have to be protected by a fuse.

Examples of application

Protective measure for mobile generators: "Protection by electrical separation with insulation monitoring and disconnection"

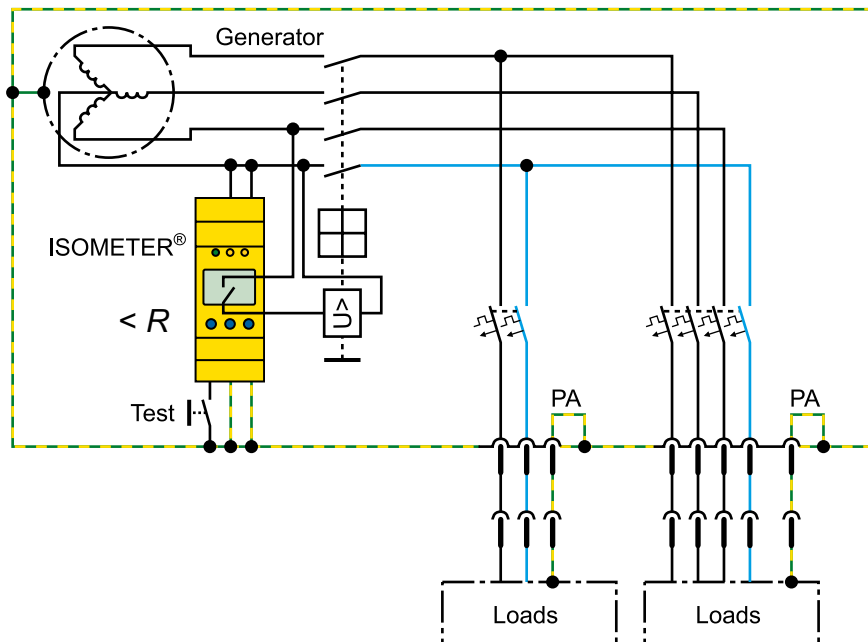

Setting K1/K2 for **overvoltage release**: N/O operation (n.o.); Fault memory setting: OFF

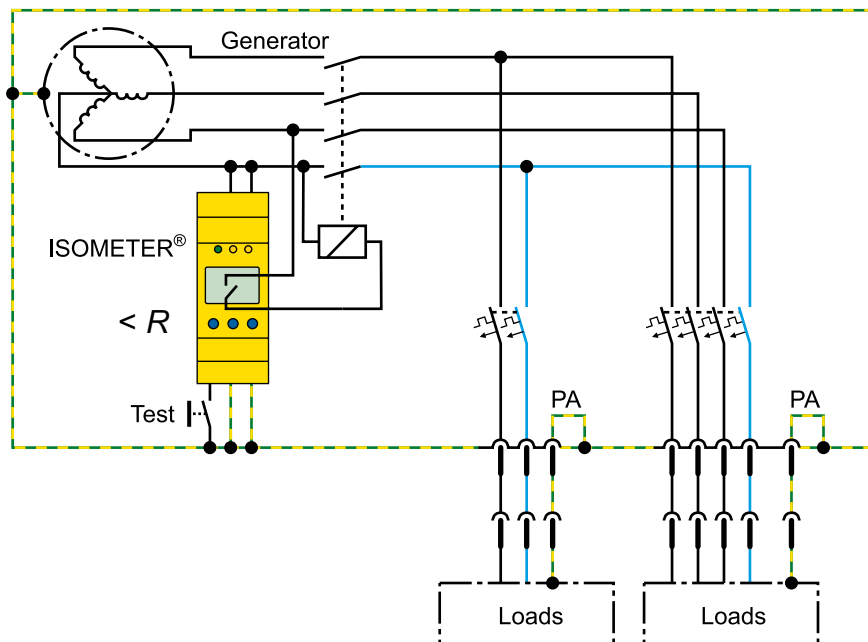

Setting K1/K2 for **contactor**: N/C operation (n.c.), fault memory setting: ON

Technical data
Insulation coordination acc. to IEC 60664-1/IEC 60664-3

Rated insulation voltage	250 V
Rated impulse voltage/pollution degree	4 kV/3
Protective separation (reinforced insulation) between (A1, A2) - (L1, L2, E, KE, T/R) - (11, 12, 14) - (21, 22, 24)	
Voltage test acc. to IEC 61010-1	2.21 kV

Supply voltage
IR423-D4-1:

Supply voltage U_s	AC 16...72 V / DC 9.6...94 V
Frequency range U_s	30...460 Hz / DC

IR423-D4-2:

Supply voltage U_s	AC/DC 70...300 V
Frequency range U_s	30...460 Hz, DC
Power consumption	≤ 4 VA

IT system being monitored

Nominal system voltage U_n	AC 0...300 V
Nominal frequency f_n	30...460 Hz

Response values

Response value R_{an1} (Alarm 1)	1...200 k Ω (46 k Ω)*
Response value R_{an2} (Alarm 2)	1...200 k Ω (23 k Ω)*
Relative uncertainty 1...5 k Ω /5...200 k Ω	± 0.5 k Ω / ± 15 %
Hysteresis 1...5 k Ω /5...200 k Ω	+ 1 k Ω /+ 25 %

Time response

Response time t_{an} at $R_f = 0.5 \times R_{an}$ and $C_e = 1$ μ F	≤ 1 s
Start-up delay (start time) t	0...10 s (0 s)*
Response delay t_{on}	0...99 s (0 s)*

Measuring circuit

Measuring voltage U_m	± 12 V
Measuring current I_m (at $R_f = 0$ Ω)	≤ 200 μ A
Internal DC resistance R_i	≥ 62 k Ω
Impedance Z_i at 50 Hz	≥ 60 k Ω
Permissible extraneous DC voltage U_{fg}	\leq DC 300 V
Permissible system leakage capacitance	≤ 5 μ F

Displays, memory

Display	LC display, multi-functional, non-illuminated
Display range, measured value	1 k Ω ...1 M Ω
Operating uncertainty 1...5 k Ω /5 k Ω ...1 M Ω	± 0.5 k Ω / ± 15 %
Password	off/0...999 (off)*
Fault memory (alarm relay)	on/off*

Outputs

Cable length test and reset button	≤ 10 m
------------------------------------	-------------

Switching elements

Number of switching elements	2 (changeover contact K1, K2)
Operating principle	NC or N/O operation (N/O operation)*
Electrical endurance, number of cycles	10000

Contact data acc. to IEC 60947-5-1

Utilisation category	AC-13 / AC-14 / DC-12 / DC-12 / DC-12
Rated operational voltage	230 V / 230 V / 220 V / 110 V / 24 V
Rated operational current	5 A / 3 A / 0.1 A / 0.2 A / 1 A
Contact rating	1 mA at AC/DC ≥ 10 V

Environment/EMC

EMC	acc. to IEC 61326-2-4
Operating temperature	-25...+55 °C
Option "W"	-40...+70 °C

Climatic class acc. to IEC 60721

Stationary use (IEC 60721-3-3)	3K22
Option "W"	3K23
Transport (IEC 60721-3-2)	2K11
Long-time storage (IEC 60721-3-1)	1K22

Classification of mechanical conditions IEC 60721

Stationary use (IEC 60721-3-3)	3M11
Option "W"	3M12
Transport (IEC 60721-3-2)	2M4
Long-time storage (IEC 60721-3-1)	1M12

Connection

Connection type	screw-type terminal or push-wire terminal
-----------------	---

Connection screw terminals

Connection properties	
rigid	0.2...4 mm ² (AWG 24...12)
flexible	0.2...2.5 mm ² (AWG 24...14)
Two conductors with the same cross section	
rigid/flexible	0.2...1.5 mm ² (AWG 24...16)
Stripping length	8...9 mm
Tightening torque, terminal screws	0.5...0.6 Nm

Connection push-wire terminals

Connection properties	
rigid	0.2...2.5 mm ² (AWG 24...14)
flexible	
without ferrules	0.75...2.5 mm ² (AWG 19...14)
with ferrules	0.2...1.5 mm ² (AWG 24...16)
Stripping length	10 mm
Opening force	50 N
Test opening, diameter	2.1 mm

Other

Operating mode	continuous operation
Mounting	any position
Degree of protection, internal components (DIN EN 60529)	IP30
Degree of protection, terminals (DIN EN 60529)	IP20
Enclosure material	polycarbonate
Flammability class	UL94 V-0
DIN rail mounting acc. to	IEC 60715
Screw mounting	2 x M4 with mounting clip
Weight	≤ 150 g

(*) = factory setting

Ordering information

Type	Supply voltage ¹⁾ U_s	Art. No.	
		screw terminals	push-wire terminals
IR423-D4-1	DC 9,6...94 V / AC 16...72 V, 30...460 Hz	B91016304	B71016304
IR423-D4W-1		B91016304W	B71016304W
IR423-D4-2	DC 70...300 V / AC 70...300V, 30...460 Hz	B91016305	B71016305
IR423-D4W-2		B91016305W	B71016305W

¹⁾ Absolute values

Accessories

Type designation	Art. No.
Mounting clip for screw mounting (1 piece per device)	B98060008

Dimension diagram XM420

Dimensions in mm

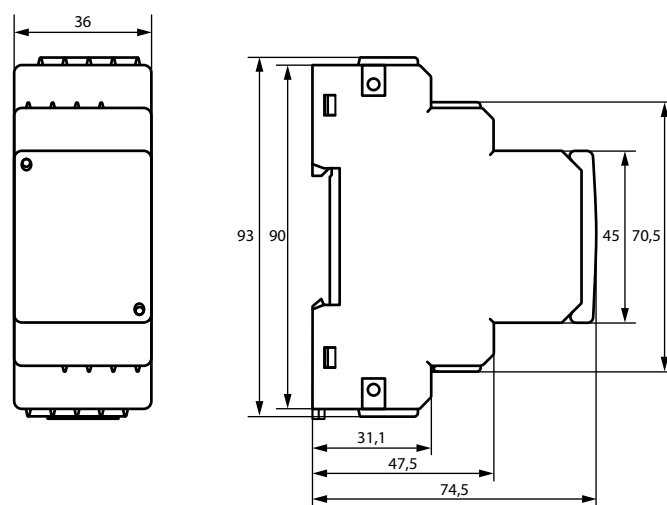

Bender GmbH & Co. KG

Londorfer Straße 65
35305 Grünberg
Germany

Tel.: +49 6401 807-0
info@bender.de
www.bender.de



© Bender GmbH & Co. KG, Germany
Subject to change!

The specified standards take into account the edition valid until 07.2024 unless otherwise indicated.