

Application note

Real-time earth leakage detection in data centres



Project aim

To increase the reliability of the data centre by implementing residual current monitoring

Project outcomes

- Enhanced safety
- Reduced downtime
- Regulatory compliance

Background

Data centres are critical business infrastructure, hosting essential IT equipment and data. As such, they require continuous operation with minimal downtime and high safety standards to prevent operational risks like system outage or fire hazards. Electrical systems within data centres are prone to faults such as insulation degradation, earth faults, or residual currents, which can lead to equipment failure, fire outbreaks, and costly operational disruptions.

Objective

Our client was upgrading their uninterruptible power supply (UPS) system in a large scale data centre. The UPS system was due for an upgrade, and our client wanted to add extra resilience by incorporating residual current monitoring (RCM) systems.

Solution

Following consultation with the client, the LINETRAXX® RCMS residual current monitoring devices were selected and supplied as part of a bespoke monitoring panel. This bespoke offering allowed for ease of installation. Although the UPS systems within this data centre varied in rating and battery configuration, the versatility of our devices meant that we could supply uniform solutions across all of their systems.

The residual current monitoring systems were installed within the UPS battery system to continuously monitor residual and fault currents, which could indicate insulation breakdown or other electrical faults. Our monitoring systems alert facility notifies operators as soon as residual currents exceed predefined thresholds, allowing for immediate intervention before any damage occurs.

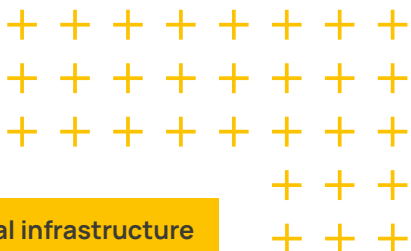

Critical infrastructure

Outcomes

The introduction of continuous residual current monitoring within the data centre UPS system offers several key advantages:

- **Enhanced Safety:** Continuous monitoring ensures that electrical faults, which can lead to overheating or fire, are detected and addressed early. The system's ability to monitor AC and DC fault currents ensures comprehensive protection.
- **Reduced Downtime:** By catching electrical faults before they cause equipment failure, Bender's solution helps to prevent unscheduled downtimes, ensuring smoother operations within the data centre.
- **Regulatory Compliance:** Bender monitoring solutions assist data centres in meeting fire protection and electrical safety regulations, reducing the burden of manual compliance checks and reporting.

RCMS425



Data centre solutions

In addition to residual current monitoring, we offer a wide range of solutions for data centres, including insulation monitoring, condition monitoring, and communication and alarm software.

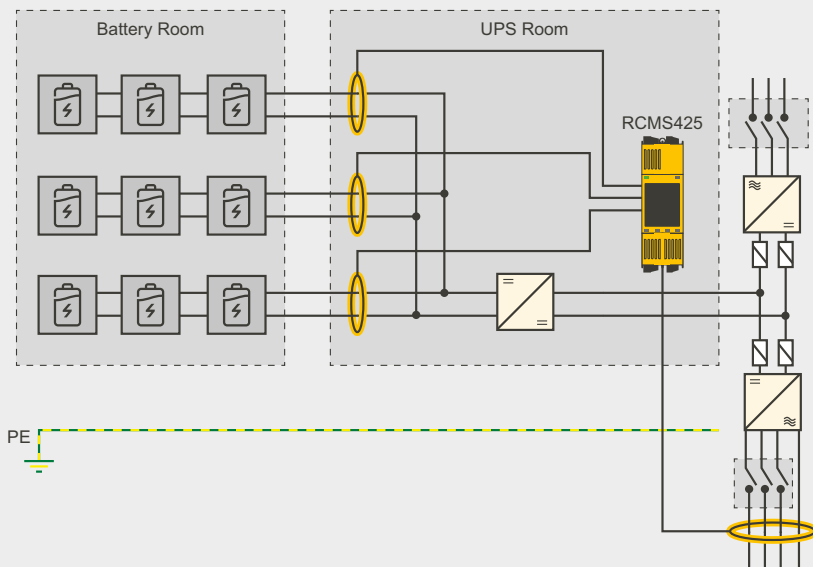

DC earth fault detection with residual current monitor device RCMS425

Bender is an expert in developing smart, safer, and more sustainable energy solutions that protect critical industries worldwide.

A trusted partner, delivering pioneering solutions that optimise productivity, reliability, and efficiency.



Visit our website for more information

Bender GmbH & Co. KG
 Londorfer Straße 65
 35305 Grünberg
 Germany

Tel.: +49 6401 807-0
 info@bender.de
 www.bender.de/en

